

TOWN OF VOLUNTOWN
DRIVEWAY ORDINANCE

SECTION I. Definitions:

Applicant: the term "Applicant" refers to the person proposing a driveway.

Board: the Board of Selectmen for the Town of Voluntown, CT or their authorized representative.

Business/Commercial: the retail sale of goods and services.

Commission: the Planning Commission of the Town of Voluntown, CT or their authorized representative.

Driveway: an access onto or an egress from a street.

Industrial: the storage, manufacturing and processing of goods, wholesaling and related storage, research laboratories, general office space, printing and publishing establishments and bulk storage of cement and petroleum products.

New Driveway: an access onto or an egress from a street that was not in existence on or before the adoption date of this ordinance, or an existing access or an existing egress from a street, where the use of that driveway has changed.

Person: includes corporations, partnerships, firms, associations and/or any other entity.

Residential Dwelling Unit: a building or portion thereof containing complete housekeeping facilities.

Road Standards: shall mean the standards and specifications set forth in the Public Improvements Specifications prepared by the Northeastern Connecticut Council of Governments, 1988 as amended.

Street/Road: any town maintained way constructed for and dedicated to movement of vehicles and pedestrians. The word shall not include private driveways and rights-of-way (R.O.W.).

Town: the Town of Voluntown, CT.

SECTION II: Purpose:

It is the declared purpose of this ordinance to regulate driveways for the purpose of providing safe and structurally adequate access onto streets.

SECTION III. Procedure:

1. No person shall construct a new driveway or relocate an existing driveway leading into a town road without first obtaining a written permit from the Board of Selectmen of the Town of Voluntown, CT.
2. No building permit(s) will be issued until the applicant has applied for and received a Driveway Construction Permit.
3. Construction may start only after issuance of the Driveway Construction Permit. The Board must be notified two (2) working days in advance of: the start of construction; finishing the subgrade; finishing the base; and surfacing. The Board will then inspect the work at each phase.
4. Final Approval of the driveway will be issued by the Board when all work is completed in accordance with the standards as verified by the inspections.
5. No Certificate of Occupancy will be issued until the Board issues its final approval of the driveway.
6. Application shall be made to the Board of Selectmen on a form provided by the Board. A sketch plan showing proposed dimensions and location of driveway and lot boundaries and a fee of twenty-five dollars (\$25.00) and a cash bond of one thousand dollars (\$1,000.00) OR an amount equal to the amount of construction proposed as estimated by the Board, whichever is greater, must accompany the application. The applicant will be issued a Driveway Construction Permit only if all required standards are met and a bond has been posted. Construction must be completed one year from the date of permit issuance.

SECTION IV. Standards:

The following standards shall apply to all new residential, business/commercial, and industrial driveway construction:

1. One (1) residential unit (figure 1., figure 2 and figure 3).
2. Two (2) residential units (figure 1., figure 2 and figure 4).
3. Three (3) residential units (figure 1, figure 2, and figure 5).
4. Business/Commercial (figure 6, and figure 7).

5. Industrial (figure 6, and figure 8).

The following standards shall also apply to all new driveway construction:

6. Driveways shall intersect streets at an angle of approximately ninety (90) degrees and shall be located and designed with satisfactory sightlines along the subject state or town roads. Driveways comply with the minimum state recommended sight distances for the established speed limit when entering a state highway and shall have a minimum sight distances of two hundred and seventy-five (275) feet when entering a town road.
7. Driveways shall be designed to prevent storm water flows from entering a town street and, wherever possible, the town right-of-way. Privately owned and maintained drainage diversion swales, detention areas, and/or dry wells shall be utilized to the greatest extent possible. Culverts, with a minimum diameter of fifteen (15) inches, shall be used when crossing town drainage ways. Whenever a private swale or private detention area is utilized in diverting driveway water from the town right-of-way, the owner of the subject lot(s) shall be responsible for maintaining the swale or detention area and any culverts in accordance with the approved design.
8. A maintenance agreement signed by the owner of the land, shall also be submitted. After issuance of the permit, such maintenance agreement shall be recorded on the land records to ensure compliance by subsequent owners.
9. The Board of Selectmen may waiver specific "Standards" (section 4), within this ordinance if; the standard(s) waived, do not decrease the safety of, and/or the structural adequacy of, any "New Driveway."

SECTION V. Inspection Fees:

The applicant shall pay the following inspection fees: fifty dollars (\$50.00) for two (2) residential units; seventy-five dollars (\$75.00) for three or more residential units, non-residential driveways and other improvements within the town road limits shall pay an inspection fee equal to 10% of the construction cost estimated by the Board. Non-residential inspection fees will be put into a separate Inspection Fee Account. Inspection costs (Direct + Any Indirect) will be deducted from the applicant's Inspection Fee Account and the balance will be returned to the applicant within ninety (90) days from the date that the Board issues its final driveway approval.

SECTION VI. Violation:

Failure of any person constructing or locating such new driveway to first obtain such a permit shall constitute a violation of the ordinance and any such person shall be subject to the penalties provided in section 7-148 of the Connecticut General Statutes, revision of 1958, as amended. Each day such driveway is permitted or suffered to remain shall constitute a separate violation.

SECTION VII. Effective Date:

This ordinance shall become effective as prescribed under the Connecticut General Statutes.

Effective July 10, 1993

Amended June 25, 1998

Town of Voluntown

| DIMENSIONS | | |
|------------|------|------|
| DIM. | MIN. | MAX. |
| A | 22' | 26' |
| B | 12' | 20' |
| C | 10' | --- |
| R | 5' | 8' |

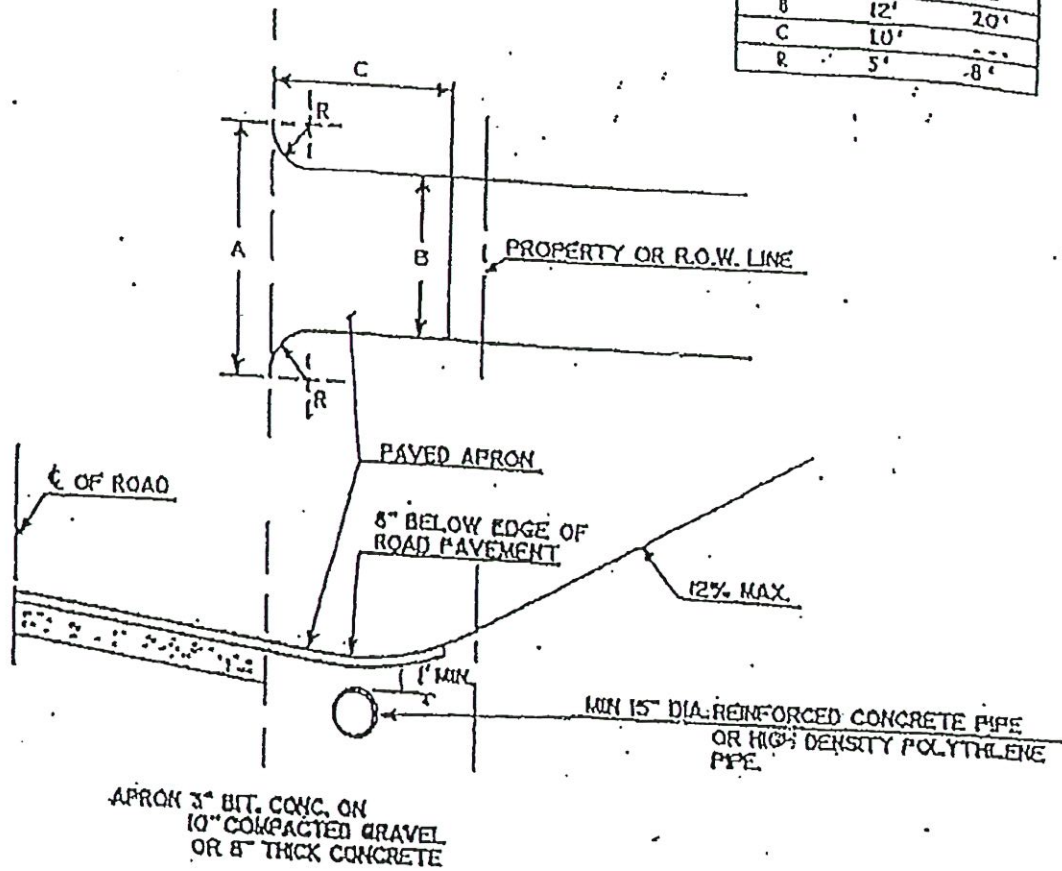

SAG CURVE IN DRIVEWAY

NOT TO SCALE

Fig 1
RESIDENTIAL DRIVEWAY DETAIL

| DIMENSIONS | | |
|------------|------|------|
| DIK. | MIN. | MAX. |
| A | 22' | 36' |
| B | 12' | 20' |
| C | 10' | --- |
| R | 5' | 8' |

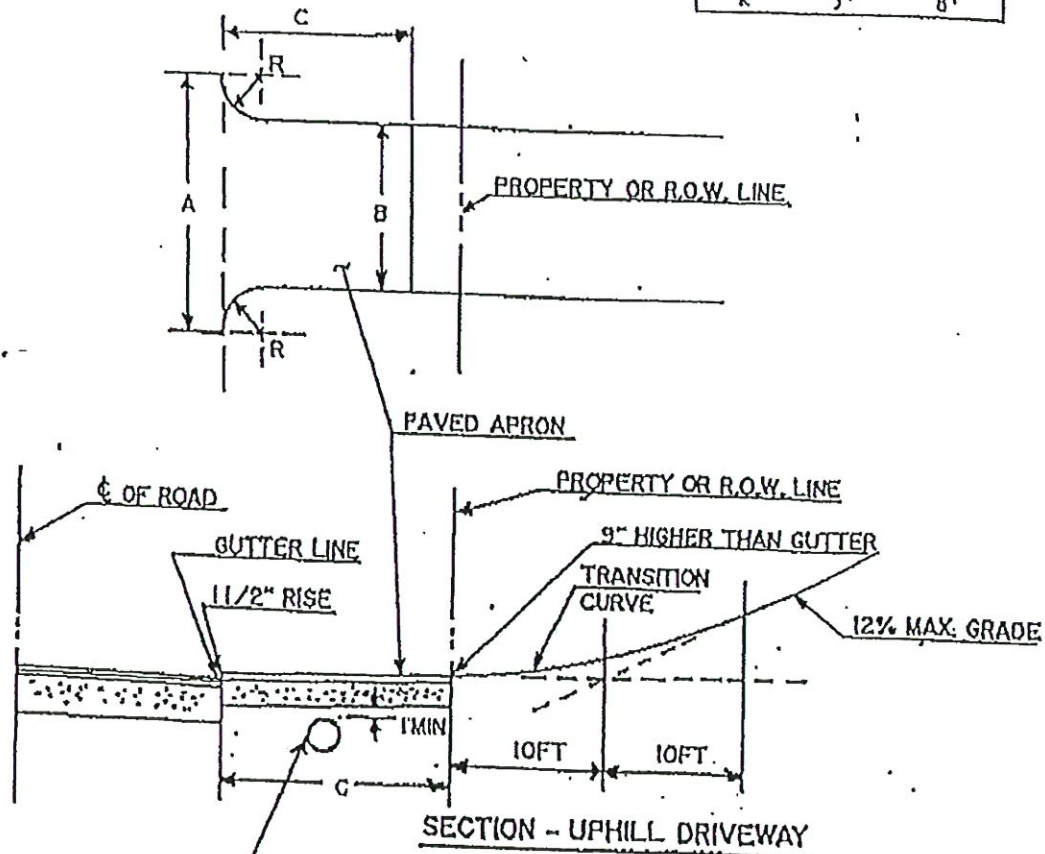

PIPE AS REQUIRED FOR EXISTING OR PROPOSED ROADSIDE SWALE - MIN 15" DIA. REINFORCED CONC. PIPE OR HIGH DENSITY POLYTHYLENE PIPE.

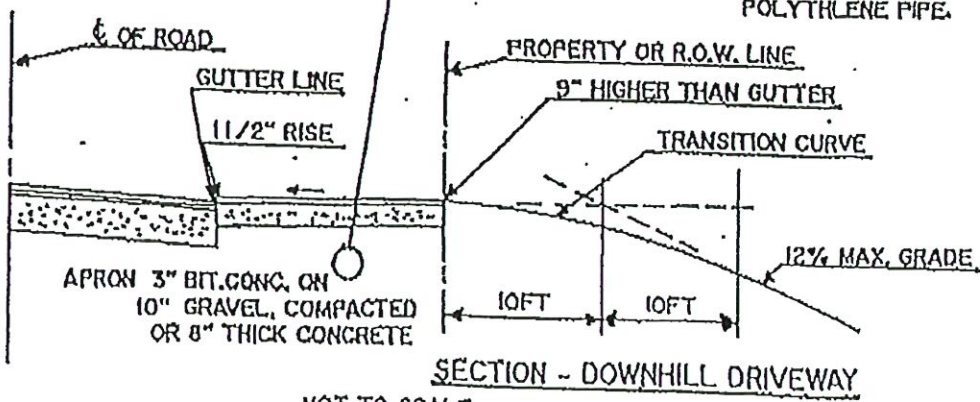

NOT TO SCALE

RESIDENTIAL DRIVEWAY DETAILS Fig. 2

Town of Voluntown

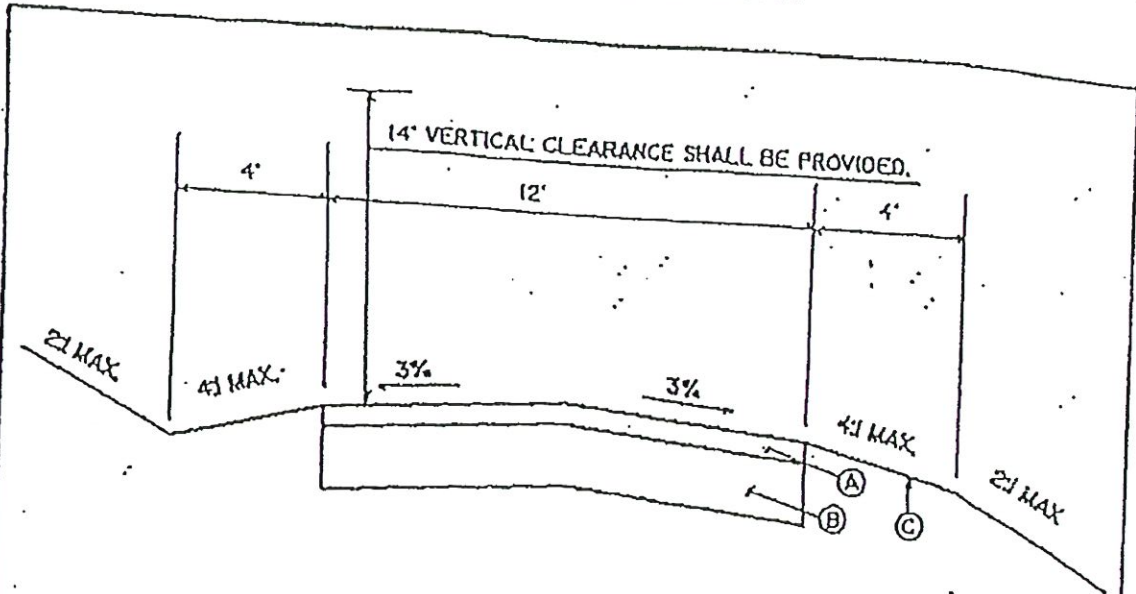

- (A) 2" PROCESSED GRAVEL
- (B) 10" COMPACTED GRAVEL
- (C) GRASSED AREA

MAXIMUM PERMITTED DRIVEWAY GRADE IS 12%.

FOR A DRIVEWAY GRADE GREATER THAN 8% THE DRIVEWAY SHALL BE PAVED STARTING AT THE 5% GRADE LIMITS. PAVEMENT SHALL BE 3" BITUMINOUS CONCRETE INSTALLED IN 2 COURSES.

DRIVEWAY STORM DRAINAGE CULVERTS SHALL MEET THE CURRENT NORTHEASTERN CONNECTICUT COUNCIL OF GOVERNMENTS "PUBLIC IMPROVEMENT SPECIFICATIONS".

TYPICAL DRIVEWAY CROSS SECTION FOR
ONE SINGLE FAMILY RESIDENCE

NOT TO SCALE

Town of Voluntown

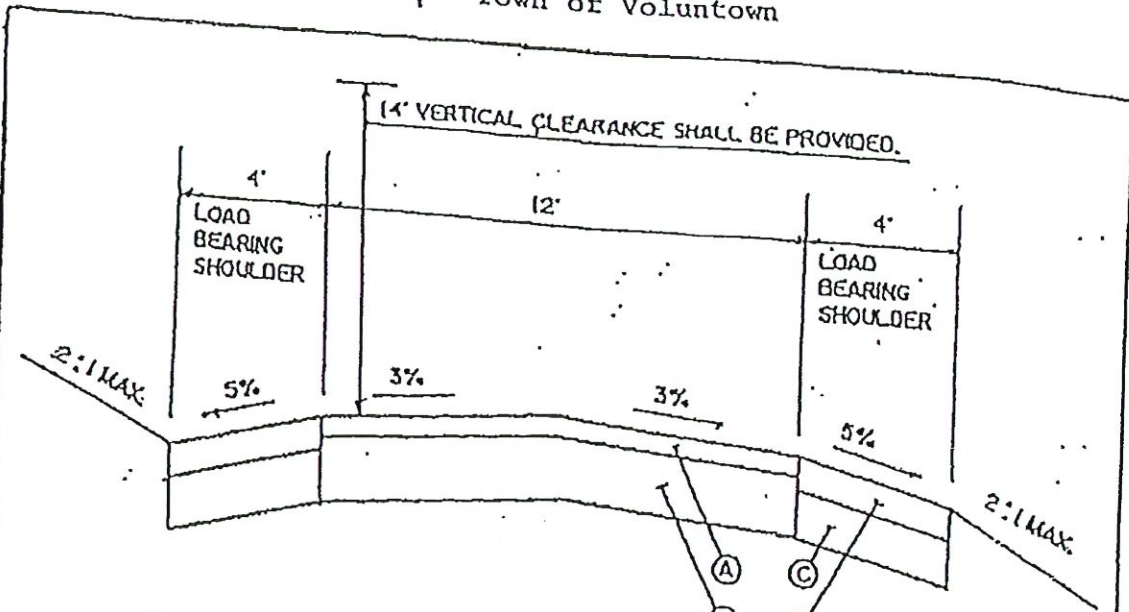

- Ⓐ 2" - 3/4" PROCESSED TRAP ROCK
- Ⓑ 10" COMPACTED GRAVEL
- Ⓒ 8" COMPACTED GRAVEL
- Ⓓ TOPSOIL

MAXIMUM PERMITTED DRIVEWAY GRADE IS 12%.

FOR A DRIVEWAY GRADE GREATER THAN 8% THE DRIVEWAY SHALL BE PAVED STARTING AT THE 5% GRADE LIMITS. PAVEMENT SHALL BE 3" BITUMINOUS CONCRETE INSTALLED IN 2 COURSES.

DRIVEWAY STORM DRAINAGE CULVERTS SHALL MEET THE CURRENT NORTHEASTERN CONNECTICUT COUNCIL OF GOVERNMENTS "PUBLIC IMPROVEMENT SPECIFICATIONS".

TURN OFFS OF 30' LONG x 10' WIDE SHALL BE PROVIDED EVERY 300'.

TYPICAL COMMON DRIVEWAY CROSS SECTION FOR TWO RESIDENCES.

NOT TO SCALE

Fig 4

Town of Voluntown

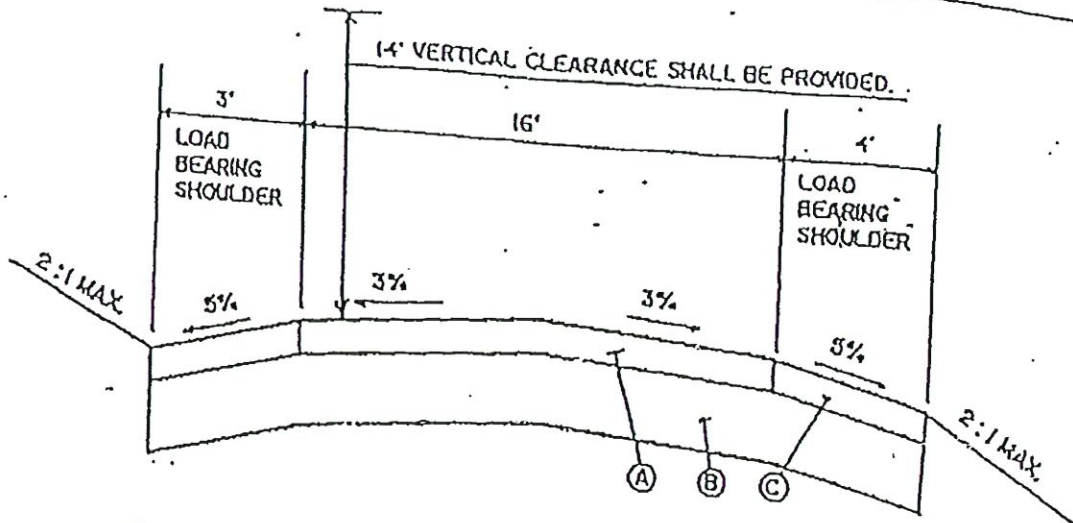

- (A) 4" - 1 1/4" PROCESSED TRAP ROCK
- (B) 10" COMPACTED GRAVEL
- (C) TOPSOIL

MAXIMUM PERMITTED DRIVEWAY GRADE IS 12%.

FOR A DRIVEWAY GRADE GREATER THAN 8% THE DRIVEWAY SHALL BE PAVED STARTING AT THE 5% GRADE LIMITS. PAVEMENT SHALL BE 3" BITUMINOUS CONCRETE INSTALLED IN 2 COURSES.

DRIVEWAY STORM DRAINAGE CULVERTS SHALL MEET THE CURRENT NORTHEASTERN CONNECTICUT COUNCIL OF GOVERNMENTS "PUBLIC IMPROVEMENT SPECIFICATIONS".

TURN OFFS OF 30' LONG x 10' WIDE SHALL BE PROVIDED EVERY 300'.

TYPICAL COMMON DRIVEWAY CROSS SECTION FOR THREE OR MORE RESIDENCES.

NOT TO SCALE

Fig. 5

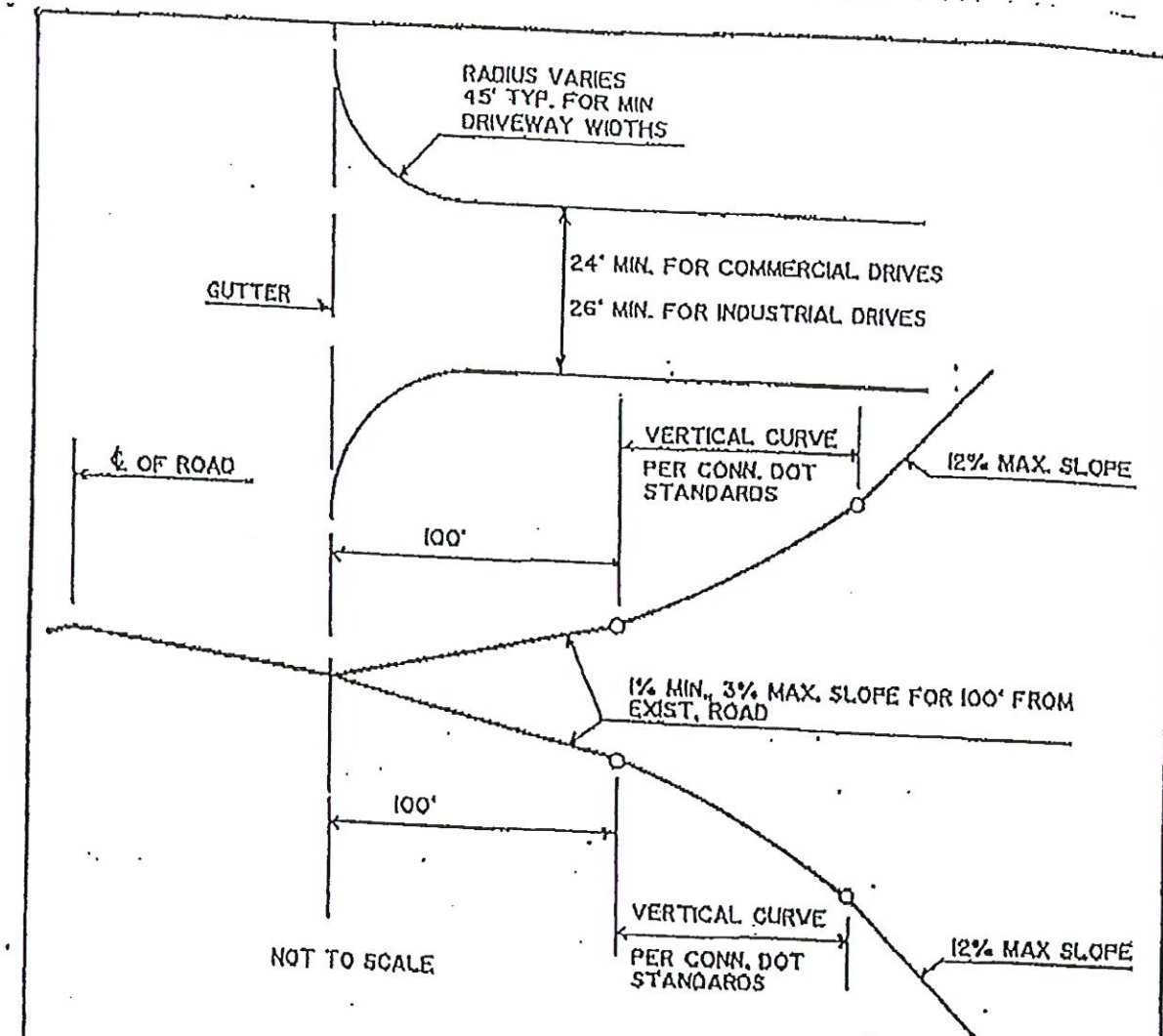

NOTES: INTERSECTIONS TO BE DESIGNED FOR '48-50 VEHICLE. MINIMUM FORTY FIVE FOOT RADIUS WILL BE REQUIRED FOR 26' (OR LESS) WIDE DRIVEWAYS.

SIGHT LINES TO BE PROVIDED PER CONN DEPT. OF TRANSPORTATION GUIDELINES.

STORM DRAINAGE TO BE PROVIDED PER CONN DEPT. OF TRANSPORTATION GUIDE LINES. REINFORCED CONCRETE PIPE MINIMUM DIAMETER OF 15" TO BE USED.

PROPOSED INDUSTRIAL/COMMERCIAL DRIVEWAYS SHALL BE PAVED PER TOWN DRIVEWAY STANDARDS.

THE REQUIRED 1 1/2 MIN - 3% MAX SLOPE FOR THE FIRST 100 FEET AT A DRIVEWAY INTERSECTION MAY BE REDUCED TO 3% FEET WITH APPROVAL OF TOWN ENGINEER.

COMMERCIAL - INDUSTRIAL DRIVEWAY DETAILS

Fig. 6

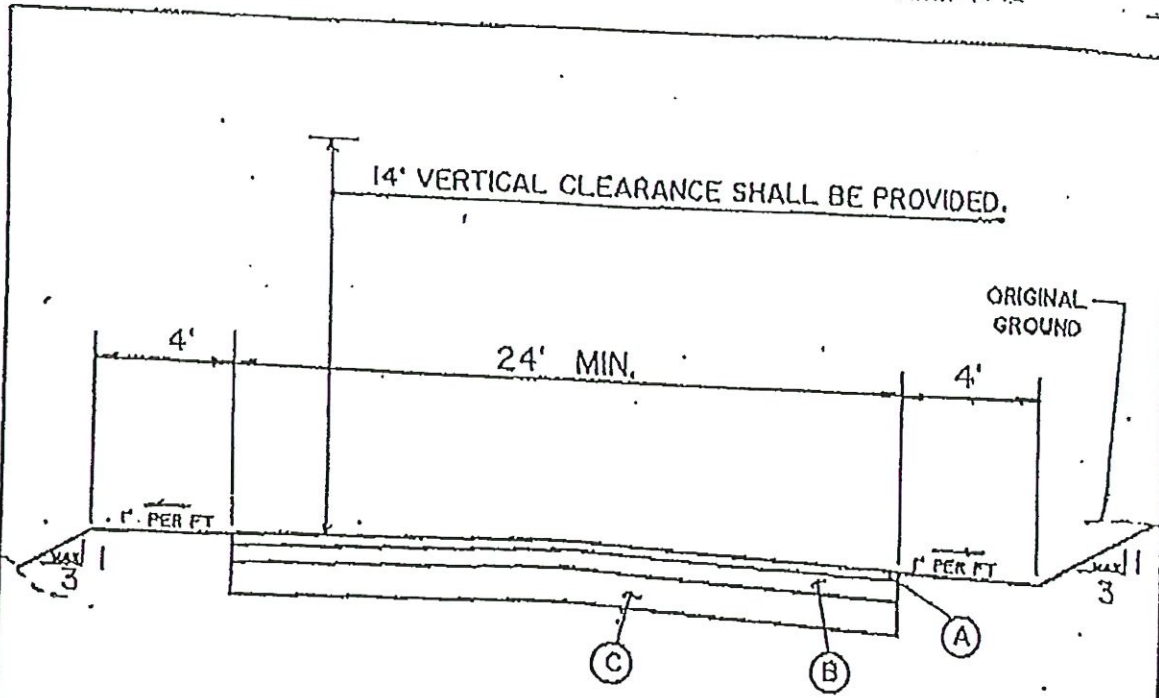

- Ⓐ 1 1/2" COMPACTED PREMIXED BITUMINOUS BASE & 1 1/2" COMPACTED BITUMINOUS SURFACE COURSE
- Ⓑ 6" PROCESSED STONE AGGREGATE
- Ⓒ 12" MIN. COMPACTED GRAVEL SUBBASE

DRIVEWAY STORM DRAINAGE CULVERTS SHALL MEET THE CURRENT NORTHEASTERN CT COUNCIL OF GOVERNMENTS "PUBLIC IMPROVEMENT SPECIFICATIONS".

TYPICAL CROSS SECTION FOR COMMERCIAL DRIVES

NOT TO SCALE

Fig. 7

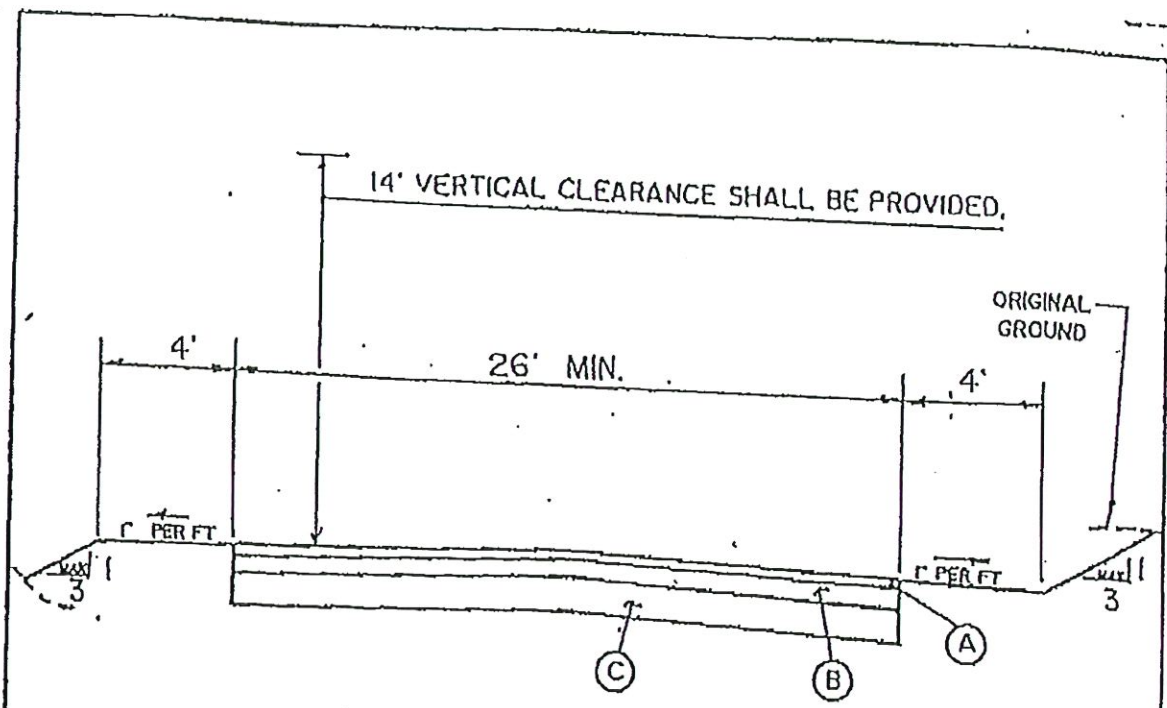

- (A) 2" COMPACTED PREMIXED BITUMINOUS BASE & 2" COMPACTED BITUMINOUS SURFACE COURSE
- (B) 6" PROCESSED STONE AGGREGATE
- (C) 12" MIN. COMPACTED GRAVEL SUBBASE

DRIVEWAY STORM DRAINAGE CULVERTS SHALL MEET THE CURRENT NORTHEASTERN CT COUNCIL OF GOVERNMENTS "PUBLIC IMPROVEMENT SPECIFICATIONS".

**TYPICAL CROSS SECTION
FOR INDUSTRIAL DRIVES**

NOT TO SCALE

Fig. 8

TOWN OF VOLUNTOWN
DRIVEWAY ORDINANCE

SKETCH PLAN

